

**HIGH INTENSITY DISCHARGE (HID) LIGHTING
EQUIPMENT MAINTENANCE DESCRIPTION (IRI-EM10-EMD)**



**INDUSTRIAL RESOURCES, INC.
A TRAINING SERVICES COMPANY**

December 15, 2003

©This document is the property of Industrial Resources, Inc. Copies and distribution of this document is prohibited unless written authorization is granted by Industrial Resources, Inc.

PREFACE

This Training Equipment Maintenance Description (EMD) has been designed to assist you in meeting the requirements of Module IRI-EM10 of the Electrical Maintenance Training Program. It contains information about the High Intensity Discharge (HID) Lighting. This includes function, quantity of parts, location of parts, description of the physical construction of the part, and description of the operation of the part, equipment preventive and corrective maintenance, and references.

You should review each chapter objective. In doing so you will be better prepared to learn the required information. You should also inspect the equipment identifying the components and controls. Should you have additional questions about the equipment, ask your supervisor.

A separate document, High Intensity Discharge (HID) Lighting Equipment Maintenance Procedure (IRI-EM10-EMP), covers detailed maintenance of the High Intensity Discharge (HID) Lighting.

HIGH INTENSITY DISCHARGE (HID) LIGHTING
TRAINING EQUIPMENT MAINTENANCE DESCRIPTION
TABLE OF CONTENTS

1.0	Introduction.....	4
1.1	Equipment Function.....	4
1.2	Equipment Description	4
1.2.1	Equipment Data	8
1.3	Equipment Connections and Interface	8
2.0	Equipment Major Parts	9
2.1	Pole-Type HID Fixture	9
2.2	HID Sports Lights	11
3.0	Equipment Preventive and Corrective Maintenance.....	13
3.1	HID Lighting Preventive Maintenance	13
3.2	HID Lighting Corrective Maintenance	14
4.0	References.....	16

List of Figures:

- Figure 1 – Sulfur Lamp Size Comparison
- Figure 2 – Light Wave Spectrum from Sulfur Lamp
- Figure 3 – Basic Sulfur HID Light
- Figure 4 – Sulfur HID Light with Light Tube Diagram
- Figure 5 – Pole-Type HID Fixture
- Figure 6 – Pole-Type HID Fixture Diagram
- Figure 7 – HID Sports Floodlight
- Figure 8 – Sports Floodlight Diagram

1.0 Introduction

Chapter Objectives:

Describe the functions of the HID Lighting equipment.

1. State, from memory, the functions of the HID Lighting equipment.
2. Draw a simplified arrangement of the HID Lighting equipment.
3. Describe the flow path and how the HID Lighting equipment is operated and maintained.
3. List the normal HID Lighting operating parameters.

1.1 Equipment Function

The function of the High Intensity Discharge (HID) Lighting is to illuminate areas throughout the campus.

1.2 Equipment Description

High Intensity Discharge (HID) Lighting provides illumination for many areas around the IRI campus, including the stadium, parking garages, building entry areas and walkways. HID lights are used because they provide a large amount of light (lumens) in the area being lit at a low cost compared to other types of lights. In addition, the service life is longer than many other types of lighting. While there are many types of lamps available, a relatively new type of light is used throughout the campus – the sulfur HID lamp.

The basic sulfur HID light is made up of:

1. Ballast (Microwave Source)
2. Sulfur Lamp
3. Reflector
4. Light Tube

The function of each of these components is described below.

The ballast converts the electrical energy supplied to it into microwaves. The microwaves are directed into the sulfur lamp. The sulfur lamp is made up of a spherical quartz bulb filled with a small amount of sulfur and an inert gas, such as argon. The sulfur lamp is much smaller than the incandescent HID light bulb of the same intensity (**Figure 1**).



Figure 1 - Sulfur Lamp Size Comparison

The microwaves acting on the argon gas and causes it to ionize. The hot argon heats the sulfur and causes it to vaporize. The gaseous sulfur then gives off lights waves. (Unlike other gases used in lighting, such as fluorescent lights, the light waves given off by the sulfur has a broad spectrum. This means that the light is very similar to sunlight, but contains no ultra-violet light. This makes the light appear more natural.)

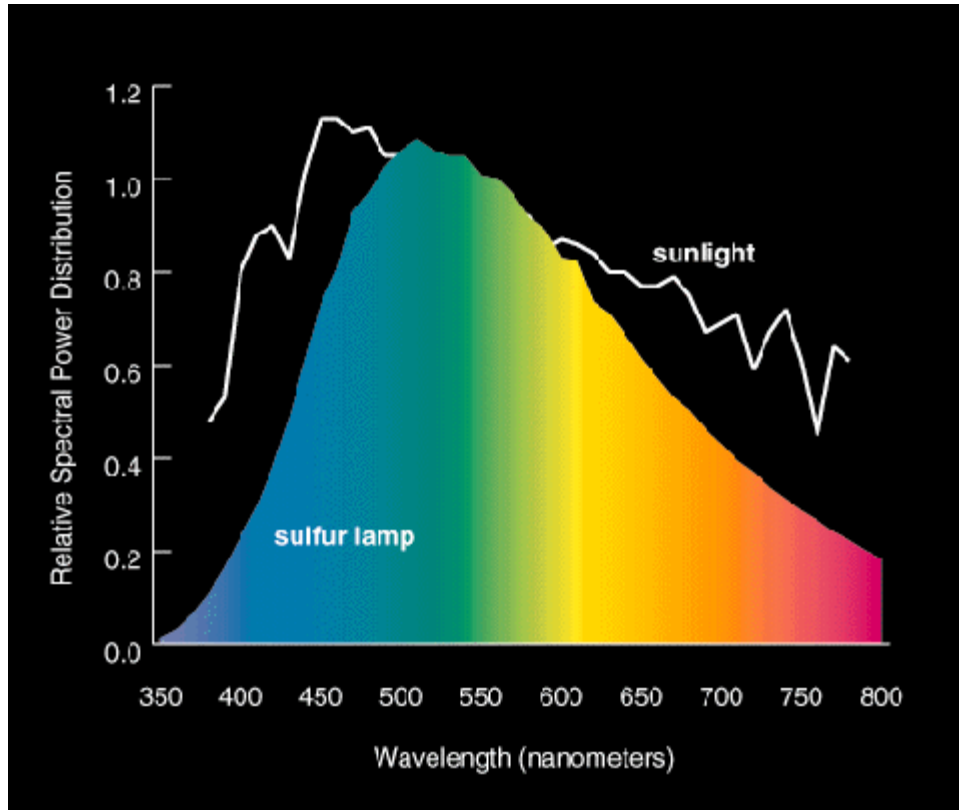

Figure 2 - Light Wave Spectrum from Sulfur Lamp

The basic sulfur HID light (**Figure 3**) may be used for small area lighting, such as in an entryway or along a sidewalk. A reflector directs the light onto the area being illuminated.

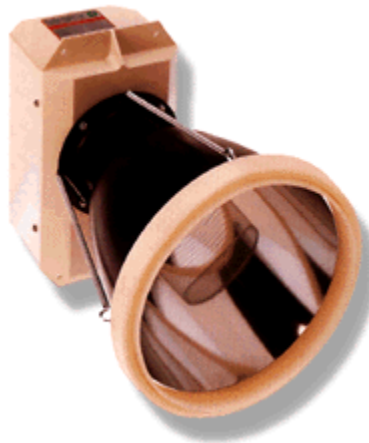

Figure 3 - Basic Sulfur HID Light

The HID light may also be used with a light pipe, as illustrated in **Figure 4**. The light given off by the sulfur bulb passes into a reflector. The purpose of the reflector is to direct the light into the light tube. Light enters the light tube as a cone. The light tube is an acrylic tube and a mirror at the opposite end from the sulfur lamp. The inside of the tube is coated with a prismatic reflecting film. As light strikes the inside of the tube (A in **Figure 4**), most is reflected into the tube (C), though some can escape through the tube (B). The light that escapes makes the tube appear to glow. Light that travels all of the way down the pipe is reflected back along the tube by the mirror (D). In addition, a portion of the surface of the tube is covered with a light-extracting surface. This surface permits light to leave the pipe in a direction determined by the location of the light-extraction surface (E).

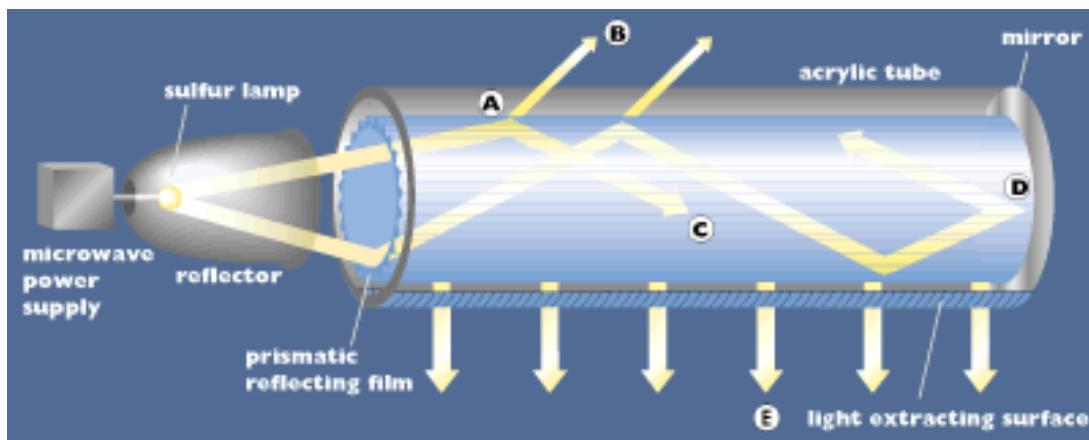

Figure 4 - Sulfur HID Light with Light Tube Diagram

Using a sulfur HID light permits supplying light to large areas, such as in a stadium or parking garage.

1.2.1 Equipment Data

Beckwith M-3425

Width	19 inches
Height	5.21 inches
Depth	10.2 inches
Weight	17 pounds
Operating Temperature	-200 C to +700 C

1.3 Equipment Connections and Interface

High Intensity Discharge (HID) Lighting receives electrical power from the low voltage distribution system. If a photocell or timer is used to control operation of the light, there will be a connection to the ballast of the HID light.

2.0 Equipment Major Parts

Chapter Objectives:

Describe how the equipment parts perform their function:

1. Draw from memory a diagram of the equipment showing major parts
2. State from memory, the names and functions of the major parts
3. Describe the location of the major parts

2.1 Pole-Type HID Fixture

The pole-type is a type of HID Fixture used to light parking areas, walkways, and other outdoor areas. The Lumark PFH Hammer and Pole Combo (**Figure 5**) is one (1) typical outdoor HID fixture.



Figure 5 - Pole-Type HID Fixture

The parts of this HID fixture (**Figure 6**) are:

1. Latches (A) – which permit opening the fixture without tools
2. Housing (B) – aluminum enclosure of HID equipment
3. Reflector (C) – anodized aluminum reflector to direct light
4. Gasket (D) – seal against ambient weather conditions
5. Door (E) – access to bulb and reflector
6. Socket (F) – electrical connection to bulb

7. Ballast Assembly (G) – water-tight compartment containing microwave source equipment
8. Pole (I) – pole which supports the fixture

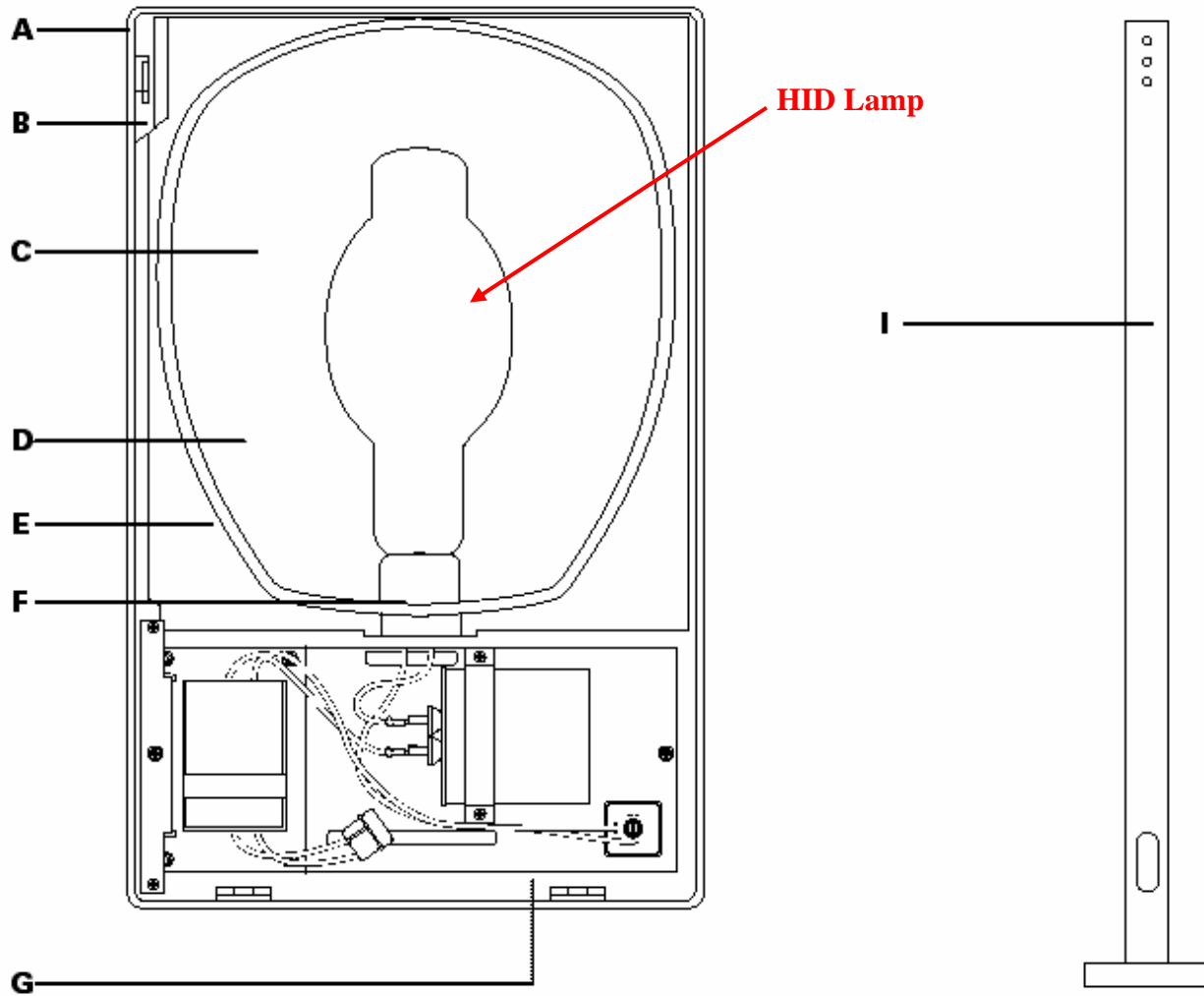

Figure 6 - Lumark Type PFH Pole-Type HID Fixture

2.2 HID Sports Lights

Another type of HID light application is lighting for a sports stadium. One (1) such light is the Streetworks EGL Sports Floodlight (Figure 7).

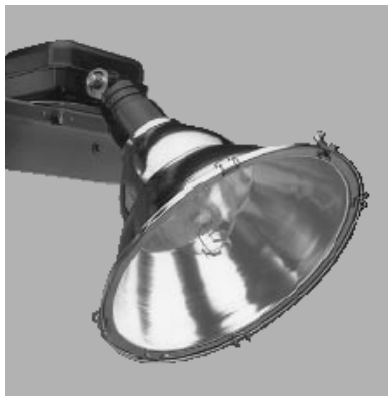

Figure 7 - HID Sports Floodlight

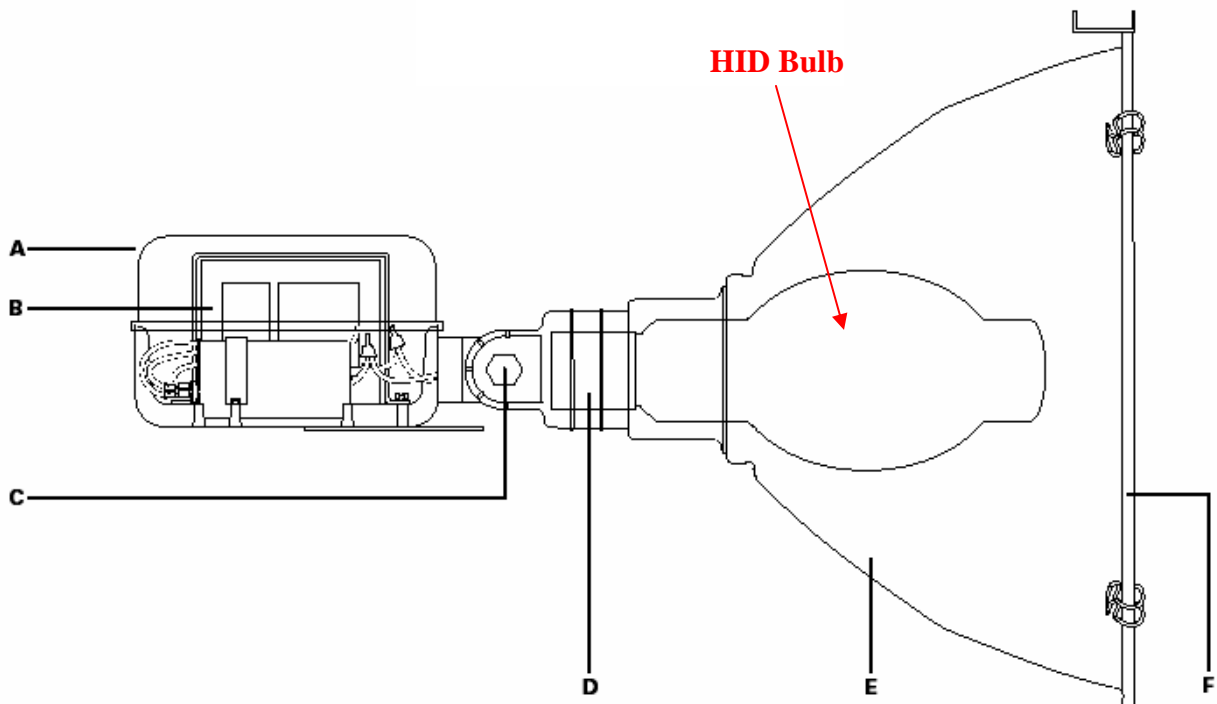

Figure 8 - HID Sports Floodlight Diagram

The parts of the Sports Floodlight are:

1. Housing (A) – aluminum water-tight housing for ballast assembly
2. Ballast (B) – microwave source assembly
3. Aiming Quadrant (C) – Adjustment to set angle of flood
4. Socket (D) – electrical connection to bulb
5. Reflector (E) – spun aluminum light reflector
6. Lens (F) – Light cover with gasket to protect bulb

3.0 Equipment Preventive and Corrective Maintenance

3.1 HID Lighting Preventive Maintenance

Preventive maintenance for HID Lighting is to visually inspect the HID light installations on a regular schedule.

For indoor installations, the following should be checked visually:

1. Fixture clear of dust buildup
2. No physical damage to fixture, bulb, or ballast assembly visible
3. Fixture mounting intact, with no sign of damage or deterioration
4. Fixture sealing gasket intact, with no sign of deterioration
5. Proper orientation of the fixture

For outdoor installations, the following should be checked visually:

1. Fixture clear of calcium or other chemical buildup due to weather
2. No physical damage to fixture, bulb, or ballast assembly visible
3. In-ground fixtures free of vegetation
4. Area around in-ground fixtures clear of standing water
5. Fixture mounting intact, with no sign of damage or deterioration
6. Fixture sealing gasket intact, with no sign of deterioration
7. Proper orientation of the fixture

To visibly check each bulb, look for the following:

1. Cracks in the outer envelope
2. Broken arc tubes
3. Cracks or seal leakage where envelope meets the base
4. Blackening of the ends of the arc tube
5. Leakage of sodium from the sodium bulb
6. Proper bulb installed for the fixture

To visibly check each HID light ballast, look for the following:

1. Insulation damage
2. Coil damage
3. Loose or disconnected leads
4. Proper ballast installed for the fixture

If any problems are found, they should be corrected as soon as possible.

3.2 HID Lighting Corrective Maintenance

Corrective maintenance consists of replacing HID lamps and, if required due to damage, HID ballast assemblies. Replacement bulbs and ballast assemblies must match the voltage and power ratings of the faulty equipment. Expected end of life for HID lamps is longer than that of incandescent bulbs. Near the end of life, high pressure sodium HID lamps cycle on and off. (This happens because the lamp requires higher voltage than the ballast is able to produce.) When this occurs, the lamps might blacken at the base of the bulb. In addition, the envelope may have discolored spots due to sodium buildup. Low pressure sodium lights simply fail to turn on at the end of life.

If one (1) or more HID lamps do not operate when turned on by a light sensor, time, or switch, do the following:

1. Check the lamp for correct voltage and wattage.
2. Verify that each lamp is properly seated in the fixture. Avoid tightening too much.
3. Verify that the power source has the correct voltage.
4. Replace each defective bulb with the correct bulb for the fixture.

If one (1) or more HID lamps cycle, do the following:

1. If the lamp is near the expected end of life, replace the bulb with the correct bulb for the fixture.
2. If the lamp is not near the expected end of life, check the electrical distribution system for heavy motor loads on the system.
3. If the lamp is not near the expected end of life, check the photocell or timer for proper operation.

If one (1) or more HID lamps have a low light output, do the following:

1. Check the voltage supply.
2. If the ballast is a multi-tap ballast, verify that the electrical connection is made to the proper tap.
3. Check for loose or damaged electrical connections.
4. Check the capacitor for damage or failure, replacing as necessary.

4.0 References

Cooper Lighting Technical Information

**HIGH INTENSITY DISCHARGE (HID) LIGHTING
TRAINING EQUIPMENT MAINTENANCE PROCEDURE (IRI-EM01-EMP)**



**INDUSTRIAL RESOURCES, INC.
A TRAINING SERVICES COMPANY**

December 15, 2003

©This document is the property of Industrial Resources, Inc. Copies and distribution of this document is prohibited unless written authorization is granted by Industrial Resources, Inc.

PREFACE

This Training Equipment Maintenance Training Procedure (EMP) has been designed to assist you in meeting the requirements of Module IRI-EM01 of the Electrical Training Program. It contains information pertaining to maintenance of the High Intensity Discharge (HID) Lighting. This includes purpose, precautions, limits and setpoints, procedures and references for maintaining equipment.

You should also inspect the equipment, identifying its components and controls. Should you have additional question about the equipment maintenance, ask your supervisor.

HIGH INTENSITY DISCHARGE (HID) LIGHTING
TRAINING EQUIPMENT MAINTENANCE PROCEDURE

TABLE OF CONTENTS

I.	Purpose.....	0
II.	Precautions, Limitations, and Setpoints	0
III.	Procedure.....	1
	A. HID Lighting Preventive Maintenance.....	1
	B. HID Lighting Corrective Maintenance	2

I. Purpose

This procedure provides information and guidance for the correct and safe use and maintenance of the M-3425 Relay Module.

II. Precautions, Limitations, and Setpoints

- A. Dangerous voltages, capable of causing death or serious injury, are present on the external terminals and inside the equipment. Use extreme caution and follow all safety rules when handling, testing, or adjusting the equipment.
- B. Do not tighten HID lamps in sockets too tightly.
- C. Make sure all HID lamps and ballast assemblies are replaced with the proper lamp and ballast for the fixture.
- D. Do not replace any component while the module is energized.
- E. To avoid electrical shock, always disconnect power and discharge circuits before working on the module.
- F. Do not perform any unauthorized modifications on the module.
- G. Before attempting any test, calibration, or maintenance procedure, personnel must be completely familiar with the circuitry of the module and have an adequate understanding of the field devices connected to the module.
- H. Follow all applicable safety procedures when performing any maintenance.

III. Procedure

The following procedures provide detailed instructions for conducting routine operations, as well as preventive and corrective maintenance on High Intensity Discharge (HID) lighting.

A. **HID Lighting Preventive Maintenance**

HID Lighting should be regularly inspected in accordance with the following steps.

- __1. For indoor installations, the following should be checked visually:
 - a. Fixture clear of dust buildup
 - b. No physical damage to fixture, bulb, or ballast assembly visible
 - c. Fixture mounting intact, with no sign of damage or deterioration
 - d. Fixture sealing gasket intact, with no sign of deterioration
 - e. Proper orientation of the fixture

- __2. For outdoor installations, the following should be checked visually:
 - a. Fixture clear of calcium or other chemical buildup due to weather
 - b. No physical damage to fixture, bulb, or ballast assembly visible
 - c. In-ground fixtures free of vegetation
 - d. Area around in-ground fixtures clear of standing water
 - e. Fixture mounting intact, with no sign of damage or deterioration
 - f. Fixture sealing gasket intact, with no sign of deterioration
 - g. Proper orientation of the fixture

- __3. To visibly check each bulb, look for the following:
 - a. Cracks in the outer envelope
 - b. Broken arc tubes
 - c. Cracks or seal leakage where envelope meets the base
 - d. Blackening of the ends of the arc tube

- e. Leakage of sodium from the sodium bulb
- f. Proper bulb installed for the fixture

- __4. To visibly check each HID light ballast assembly, look for the following:
 - a. Insulation damage
 - b. Coil damage
 - c. Loose or disconnected leads
 - d. Proper ballast installed for the fixture

B. HID Lighting Corrective Maintenance

Use the following procedure corrective maintenance of HID lighting.

- __1. If one (1) or more HID lamps do not operate when turned on by a light sensor, time, or switch, do the following:
 - a. Check the lamp for correct voltage and wattage.
 - b. Verify that each lamp is properly seated in the fixture. Avoid tightening too much.
 - c. Verify that the power source has the correct voltage.
 - d. Replace each defective bulb with the correct bulb for the fixture.

- __2. If one or more HID lamps cycle on and off, do the following:
 - a. If the lamp is near the expected end of life, replace the bulb with the correct bulb for the fixture.
 - b. If the lamp is not near the expected end of life, check the electrical distribution system for heavy motor loads on the system.
 - c. If the lamp is not near the expected end of life, check the photocell or timer for proper operation.

- ___3. If one (1) or more HID lamps have a low light output, do the following:
 - a. Check the voltage supply.
 - b. If the ballast is a multi-tap ballast, verify that the electrical connection is made to the proper tap.
 - c. Check for loose or damaged electrical connections.
 - d. Check the capacitor for damage or failure, replacing as necessary.

**HIGH INTENSITY DISCHARGE (HID) LIGHTING
TRAINING EQUIPMENT MAINTENANCE
JOB PERFORMANCE MEASURE (IRI-EM01-JPM)**



**INDUSTRIAL RESOURCES, INC.
A TRAINING SERVICES COMPANY**

Electrical Technician

(IRI-EM01-JPM)

Performance Measure: High Intensity Discharge (HID) Lighting

Name: _____

All Parts Satisfactorily Completed:

(Supervisor's Signature)

(Date)

Supervisor's Comments: _____

References:

- Training Module IRI-EM01

Materials Needed:

- Pencil and Clipboard
- Equipment Maintenance Description – High Intensity Discharge (HID) Lighting (IRI-EM01-EMD)
- Equipment Maintenance Procedure – High Intensity Discharge (HID) Lighting (IRI-EM01-EMP)
- Associated Maintenance Checklist, Charts, Parts List, Technical Manuals

Safety/Environmental:

- Wear hard hats, safety glasses, safety toe shoe, and ear plugs as required.
- Discuss environmental hazards associated with performing maintenance of the equipment.
- Discuss any safety precaution that must be observed while performing the procedure.

Note:

Always

observe all plant safety rules in accordance with Safety and Health Procedures and all Federal, State and/or Local TOSHA Standards.

Part A: Locate Equipment

On an HID fixture, identify each of the following and explain its function, if present.

1. Ballast
2. Sulfur Bulb
3. Reflector
4. Fixture

Satisfactorily Completed _____

Part B: Controls/Breakers

Locate and identify the following:

1. Power Supply
2. Photocell or time, if present

Satisfactorily Completed _____

Part C: High Intensity Discharge (HID) Lighting Operation

This is to be performed under direction of the Shop Supervisor.

Demonstrate knowledge of the following for High Intensity Discharge (HID) Lighting equipment:

1. Explain basic operation of an HID lamp.
2. Describe the advantages of HID over other types of lighting.
3. Locate and identify at least three different types of HID fixtures.
4. Explain performance of an HID lamp near the end of service life.

Satisfactorily Completed _____

Part D: Preventive Maintenance

This is to be performed under direction of the Shop Supervisor.
Demonstrate the steps on High Intensity Discharge (HID) Lighting equipment required to perform the following preventive maintenance tasks.

Visual Inspection of Indoor Fixtures

1. Check fixture for dust buildup.
2. Check fixture and components for physical damage.
3. Check fixture for proper orientation.

Visual Inspection of Outdoor Fixtures

1. Check fixture for calcium or other chemical buildup from weather.
2. Check fixture and components for physical damage.
3. Check fixture clear of vegetation and water.
4. Check picture for proper orientation.

Visual Check of HID Bulb

1. Check outer envelope for cracks.
2. Check for broken arc tubes.
3. Check for blackening of socket or discoloration of bulb.
4. Check for sodium leakage.
5. Check that bulb is proper one for fixture.
6. Check for tightness of bulb in socket.

Visual Check of Ballast

1. Check for proper electrical connection.
2. Check for damaged or missing insulation.
3. Verify that ballast is the proper one for the fixture.

Satisfactorily Completed _____

Part E: Corrective Maintenance

This is to be performed under direction of the Shop Supervisor.
Demonstrate the steps on the High Intensity Discharge (HID) Lighting equipment required to perform the following corrective maintenance.

If Lamp Does Not Operate When Turned On

1. Check for proper voltage and wattage.
2. Verify that the lamp is properly seated, but not over-tightened.
3. Verify that the power source voltage is proper.
4. Replace defective or end-of-life bulb.

If Lamp Turns On and Off

1. If end of service life, replace the lamp.
2. If has not burned out, check the power supply.
3. Check the photocell or time that operates light.

If Lamp Has Low Output

1. Check the voltage supply.
2. Check that the proper tap on the ballast assembly is used.
3. Check for loose or damaged electrical connections.
4. Check the capacitor for damage, replacing if necessary.

Satisfactorily Completed _____

Part F: Personnel and Equipment Safety

Performed all aspects of the JPM using safe operating practices and following plant safety and environmental procedures.

Satisfactorily Completed _____

**HIGH INTENSITY DISCHARGE (HID) LIGHTING
TRAINING EQUIPMENT MAINTENANCE
TEST QUESTIONS (IRI-EM01-Q)**



**INDUSTRIAL RESOURCES, INC.
A TRAINING SERVICES COMPANY**

1. (IRI-EM01-Q) One reason that high intensity discharge (HID) lights are use is the they produce _____ than incandescent (filament) lights of the same power.
 - A. greater voltage
 - B. greater current
 - C. a greater amount of light
 - D. an equal amount of light

2. (IRI-EM01-Q) Light from a high intensity discharge (HID) light most closely resembles _____.
 - A. fluorescent light
 - B. sunlight
 - C. neon light
 - D. microwaves

3. (IRI-EM01-Q) In a sulfur bulb in a high intensity discharge (HID) lamp, the sulfur is turned to a gas by _____.
 - A. microwaves
 - B. radiowaves
 - C. X-rays
 - D. sunlight

4. (IRI-EM01-Q) The part of a high intensity discharge (HID) light that receives electrical power is the _____.
 - A. reflector
 - B. light tube
 - C. ballast
 - D. sulfur bulb

5. (IRI-EM01-Q) Near the end of life of a high pressure sodium high intensity discharge (HID) lamp, the lamp will _____.
 - A. change color of light
 - B. become more intense
 - C. turn on and stay on
 - D. turn on an off

6. (IRI-EM01-Q) Compared in size to an incandescent bulb, a sulfur bulb in a high intensity discharge (HID) light is _____.
 - A. larger
 - B. smaller
 - C. equal in size
 - D. much larger

7. (IRI-EM01-Q) The inside of a light tube used in a high intensity discharge (HID) light is coated with _____.
 - A. reflecting film
 - B. sulfur
 - C. argon
 - D. microwaves

8. (IRI-EM01-Q) When checking operation of a high intensity discharge (HID) lamp, a blackened socket is an indication of _____.
 - A. proper operation
 - B. overcurrent
 - C. end of service life of the lamp
 - D. undervoltage

9. (IRI-EM01-Q) When inspecting high intensity discharge (HID) fixtures, the area around a ground fixture should be _____.
 - A. free of dust
 - B. free of vegetation
 - C. oriented horizontally only
 - D. at least 480 Volts

10. (IRI-EM01-Q) The part of a high intensity discharge (HID) light fixture that directs the light rays is called the _____.
 - A. ballast
 - B. microwave source
 - C. sulfur lamp
 - D. reflector